

THE UNDERGROUND LAMP POST



- MINERS WERE THE FIRST ECOLOGISTS -

Vol. IV, No. 8

Spring, 1987

The Underground Lamp Post, devoted to old mine lamps, carbides, and candleholders. Mini-editor: Henry Pohs, 4537 Quitman St., Denver, Colorado, 80212

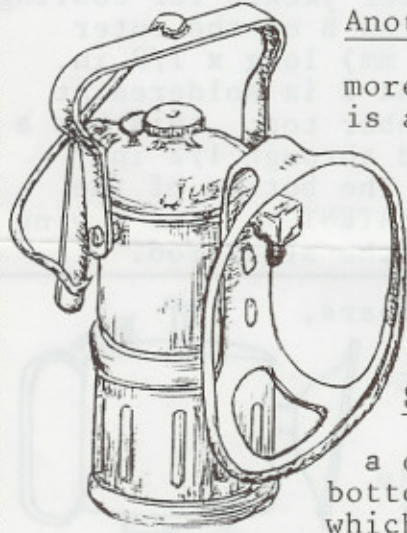

Another Justrite - John Coons, 1127 Adams St., Denver, Colorado, 80206, has shown us one more strange aberration of the Justrite series. This one is a brass carbide hand lamp, 3.125 in. (79.375 mm) in diameter x 6.5 in. (165.1 mm) tall, of a generally standard design. What is strange is the heavy steel frame, 4 in. (101.6 mm) x 5 in. (127.0 mm), that is firmly riveted to the upper water reservoir chamber. The burner tip is mounted rather high on the water reservoir. Anyone who knows what possible purpose or use this design has should contact John.

Snell Lamp - The Spring, 1982, Lamp Post showed a drawing of a carbide container bottom submitted by Steve Lofton which was marked "THE SNELL LAMP MCH. PAT. APL. FOR". Now Bill

Spence in San Jose, California, has informed us that a complete Snell lamp is in a private collection. The upper water reservoir is very similar to the well-known Ever-Ready carbide cap lamp except that the gas tube exits at about 4 PM from the top of the sphere. The original sketch provided to Bill is reproduced at the right.

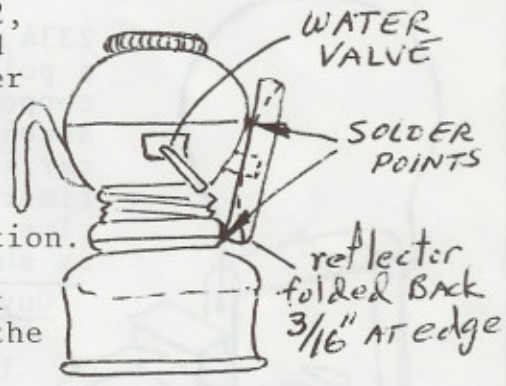

Brilliant Search Lite - William Powers, Fiddle Hill, Ashuelot, N. H., 03441, has the water reservoir top of a Brilliant Search Lite belt generator; he needs the carbide chamber bottom. If anyone has that part for sale or trade, please get in touch with Bill.

Needs and Trades - Lance and Elenore Wilson, "Talking Timbers", Murrumbateman, N. S. W. 2582, Australia, have the following items available for trade: 2 oil cap lamps (1 brass, 1 tin) stamped RA (made by Robert Anderson in Newcastle, Australia); 2 brass Broken Hill lamps; 3 Protector safety lights; Nobel detonator tins and boxes. They wish to trade for or buy the following: carbide cap lamps (most brands); miner's felt hat for use with cap lamps; blasting equipment; and any other mining related memorabilia.

Replacement Parts - Ray Zeak, 1105 Broadway, Juniata Station, Altoona, Pennsylvania, 16601, is now "spinning" (a manufacturing process) replacement reflectors for carbide cap lamps. . . Arrow, Baldwin (3 styles), Grier Bros. (vertical soldered-on), Lu-Mi-Num, and others by request as to size and style. Direct all inquiries to Ray at his address.

Trademark - Chuck Young, Route 1, Box 328-B, Marshall, Virginia, 22115, writes about the "FCH" trademark mentioned in the last Lamp Post. He always thought it might be HFC Co. and it appears on oil wick lamps and oil containers. It might be on a carbide can, too, but he wonders if it is really an oil can, although the wide opening appears to be carbide can size. Chuck had several cans, but never could locate a patent.

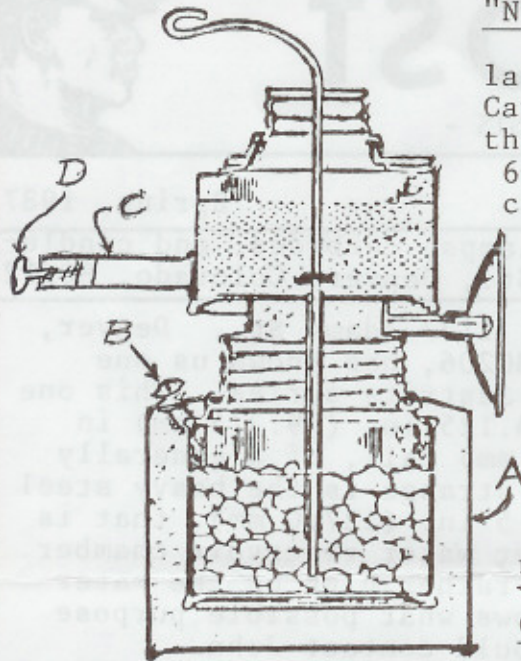

"New" News on the Old - Following Wesley Pedlow's find shown on Page 3 of the last Lamp Post, Arthur Gray, Jr., P. O. Box 292, Cave City, Arkansas, 72521, has sent the sketch at the left. His "new" lamp is black enameled tin, 6-3/4 in. (171.45 mm) tall to the top of the water cap x 3 in. (76.2 mm) in diameter. What is "new" news is the 4-1/8 in. (104.78 mm) diameter container A outside the carbide chamber bottom. It must have acted as a water jacket for cooling purposes. It has a set screw B on the outer jacket. A 1-1/2 in. (38.1 mm) long x 1/2 in. (12.7 mm) diameter steel rod C is soldered at the rear of the water chamber top; this has a perpendicular hole drilled through 1/2 in. (12.7 mm) from its end. The bottom of the outer jacket is stamped "PATENT". D is a wing nut screwed into the end of the steel rod,

Character in Copper - Dick Sears,

4831 Vespucci Drive,
Sierra Vista, Arizona, 85635-
2334, (new address), has sent us a polaroid photo of a hand-made copper carbide cap lamp he recently acquired. Scruffy and dented, it carries all the character of the old timer miner that made it in his spare time with love and care. A bare sketch is shown at the right.

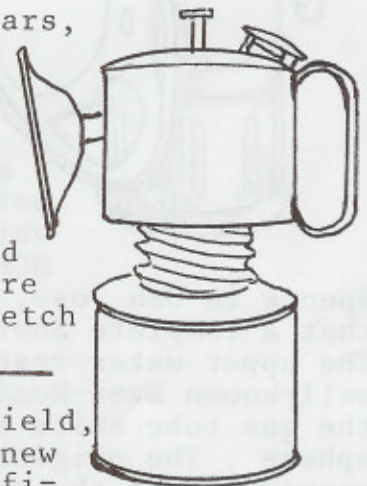

Guy's Dropper - Bob Salika, 3917
Sunnyside, Brookfield,

Illinois, 60513, is the proud new owner of the Guy's Dropper modification illustrated by his sketch to the left. Bob describes it as a 6-date, 8-hour hand lamp similar to the cap lamps, but definitely an 8-hour size. Now, who modified it and why?



South America - Mike Puhl, 3648
S. Maplewood,

Apt. A, Tulsa, Oklahoma, 74135, has sent the sketch to the right. It is a brass carbide cap lamp still being made in Boyacá, Colombia, for the local miners. It has a solid machined tip and a rubber felt retainer. Dimensions are: 3-3/4 in.

(95.25 mm) tall x 2 in. (50.8 mm) diameter x 2-3/4 in. (69.85 mm) diameter reflector. Stamping is on bottom as shown. Mike also says that he has seen a Snell lamp. It resembles the Ever-Ready except that the top is somewhat larger, the hook is round instead of flat, the tip comes straight out of the water chamber, and the bottom is soldered at the very bottom of the chamber. Mike also has seen an OKA1 (Fall, 86, Lamp Post) cardboard box from Malaysia with rubber workers pictured in the illustrations.

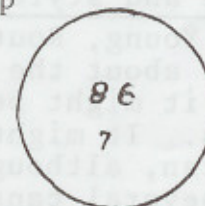
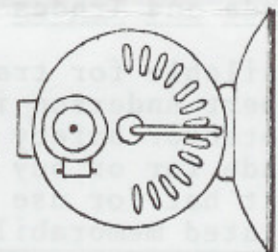

Bottom

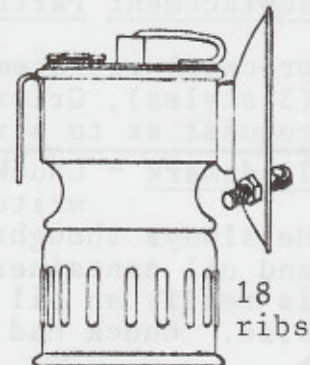

18
ribs

New Lamp Book - Bill Spence, 2381 Homewood Drive, San Jose, California, 95128, (408)247-4816, has prepared a printed reproduction of the 1905-1906 "Catalogue of the STAR, GLOBE and EAGLE . . . Miner's and Driver's Lamps" as manufactured by George Anton & Bro., Monongahela, Pa. Copies are available postpaid from Bill at his address, \$5.00 each.

Bill also inquires: "Does anyone have any kind of advertising from Ashmead or Stein (i.e., Elkhorn, Buddy, Springfield)?" and "Who has Larry Peterson's current address?"... Bill needs measurements of an early Grier lamp. Bill's contributions also include the following:

NORLEIGH DIAMOND - Registered to Norvell-Shapleigh Hardware Company of St. Louis. Application was filed January 17, 1910, issued August 2. No first usage designation. Designated class of goods was lanterns, locks and security hardware. The company which later became simply Shapleigh Hardware Company is known to have used the logo on lanterns at least as late as 1916. All of you in the St. Louis area can start beating the bushes now for Norleigh Diamond carbides. Interestingly the registration date is compatible with the known activities of the Maple City Mfg Company, which has been assumed by most collectors to have been the Norleigh's manufacturer.

CROWN - Registered to William Tunnessen of Hazleton, Pa on Sept 8, 1908. The application was filed May 28, 1908 and designated Miner's oil lamps.

IMPERIAL - Registered to Martin Hardsocg Manufacturing Company of Allegheny, Pa. Filed June 6, 1899; first used January 1, 1898; registered July 11, 1899. Class of goods covered was "certain named miners' supplies".

CHIRRY - Registered by Demmler Bros, Pittsburg, Pa on an application filed on February 19, 1889. First usage is 1878, and described class is "miners' lamps."

McMASTERS - Registered to William P. McMasters of Munhall, Pa for "miners' lamps". Filed on Sept 24, 1894; granted Nov 6, 1894; first used July 1, 1984.

VICTOR - no trademark registration, but in response to Bill's inquiry in the Spring '86 Lamp Post, Chuck Young reported that the Victor name was first reported by Vernon Hatley of Oklahoma who found one in a box with the Victor name and a picture of the lamp--no other info. Vernon, if you're among the Lamp Post's readers, Bill would like to hear from you.

Bill has just received a sketch of a mint SNELL LAMP recently found in Illinois and is happy to report that the sketch looks very much like the EverReady as he theorized in Spring '86. Can anyone shed any light on the now-likely connection between Arphad Snell and Charles Hoppe?

Bill now has a respectable trading stock of carbides (Elkhorn, Buddy, LuMiNum, Wolf, Pioneer, Justrite Victor and others) and a few miscellaneous other items. He would be happy to hear from anyone looking to trade. He's looking for any of the less common carbides--could use a Zar or Britelite for example. Contact Bill for trade list and want list.

Another Book - Robert L. Fox, 1235 N. Westfield, Oshkosh, Wisconsin, 54901, also has a new book out on oil wick cap lamps, this one on Husson Miner's Lamps. It is 16 pages, 5-1/2 in. (139.7 mm) x 8-1/2 in. (215.9 mm), and includes text and illustrations from old Oshkosh advertisements and booklets. Price is \$3.50 plus 50¢ postage.

I-Need-A-Lamp - Len Gaska, 1688 E. Corson St., Pasadena, California, 91106, writes that he needs a plastic Justrite carbide sports lamp, model 3-104 (4 in. reflector) or model 3-107 (7 in. reflector). This is the late-model plastic hand lamp with the built-in handle on the rear. Len says that it has proven to be an elusive item to find.

Cap Tin Catalog - Andy Martin, 2466 N. Treat Ave., Tucson, Arizona, 85716, has published a Cap Tin Catalog; it is available from him for \$6.00, postpaid. It features at least 150 tin illustrations from his collection. Andy says that if anyone knows of any odd ball tins not shown in his catalog, he would like them to give him a holler, as he is always trying to add new information to his listings.

Justrite Lamp Data - Dave Thorpe, 16646 N. 30th Ave, Phoenix, Arizona, 85023, has prepared the following table as a description of Justrite small-size horizontal carbide cap lamps. While other variations may exist, this table is intended to show where general design changes occurred in relation to each other. Since the bases found on lamps today are not necessarily those with which the lamp was originally manufactured, the 'base' data is included only as a rough indication of where the change in bottom design may have occurred. A horizontal line marks the location of a new change in design of a particular category.

HORIZONTAL JUSTRITE CAP LAMPS

STYLE	COND.	NB	BASE	WATER LEVER	DR	MOUNT	REFLECTOR	NOTCHES	ON/OFF	OWNER
T.J. PAF	Fair	B	Smooth	Raking wire, notched wheel	Oval	Hook, 1/4" strap	2" integral	None	None	Puhl
T.J. 1901-1912	Fair	B	Smooth	Raking wire, wheel cut-off	Oval	Hook, 1/4" strap	2" integral	None	None	Gaska
T.J. 1901-1912	Fair	N	Smooth	Raking wire, wheel cut-off	Oval	Superintendent's	2" integral	None	None	Puhl
T.J. 1901-1912	Good	B	Smooth	Raking wire, wheel cut-off	Oval	Narrow spade	2" integral	None	None	Thorpe
1901-1912	Excellent	B	Smooth	Raking wire, notched wheel	Oval	Hook, 1/4" strap	2" w/ n-silver hood	None	None	Thorpe
1901-1912	Excellent	N	Smooth	Upturned lever	Oval	Superintendent's	2" integral	12 Bumps	On(L)-Off(R)	Thorpe
1901-12-13	Very good	B	Smooth	Upturned lever	Oval	Hook, 1/4" strap	2 5/16" integral	12 Bumps	On(L)-Off(R)	Thorpe
1901-12-13	Fair	N&B	Beads	Upturned lever	Oval	Hook, 1/4" strap	2 5/16" integral	12 Bumps	On(L)-Off(R)	Young
1901-12-13	Fair	B	Beads	Upturned lever	Oval	Hook, 1/4" strap	2 1/2" integral	12 Bumps	On(L)-Off(R)	R.J.
1901-12-13	Fair	N	Beads	Upturned lever	Oval	Superintendent's	2 1/2" integral	12 Bumps	Off(R)	Gaska
1901-12-13	Fair	B	Beads	Upturned lever	Oval	Hook, 1/4" strap	2 1/2" integral	12 Bumps	Off(R)	Gaska
1901-12-13	Good	B	Beads	Upturned lever	Oval	Hook, 1/4" strap	2 5/16" integral	12 Bumps	Off(R)	Thorpe
1901-12-13	Excellent	B	Beads	SPIRAL (no spring)	Oval	Hook, 1/4" strap	2 1/2" integral	None	Off(R)	Thorpe
1901-12-13	Good	B	Beads	SPIRAL (no spring)	Oval	Hook, 1/4" strap	2 5/16" integral	17 bumps	Off(R)	Gaska
1901-12-13	Good	B	JIFFY	Upturned lever	Oval	Hook, brace gone	3" saucer integral	17 bumps	Off(R)	Thorpe
1901-12-13	Unfired	B	Beads	SPIRAL	Oval	Hook, 1/4" strap	2 5/16" integral	17 bumps	Off(R)	Thorpe
1901-12-13	Excellent	B	Beads	SPIRAL	Oval	Hook, 1/4" strap	2 1/2" integral	17 bumps	Off(R)	Thorpe
1901-12-13	Good	B	Beads	SPIRAL	Oval	Hook, 1/4" strap	3" saucer integral	17 bumps	Off(R)	Gaska
1901-12-13	Fair	B	Beads	Downturned lever (no stamp) [Lib]	Oval	Hook, 1/4" strap	2 5/26" integral	12 Bumps	Off(R)	Puhl
1901-12-13	Very good	B	Beads	Downturned lever (no stamp) [Lever]	Oval	Hook, 1/4" strap	3" saucer integral	12 Bumps	Off(R)	Thorpe
1901-12-13	Very good	B	Beads	Downturned lever (no stamp) [Lever]	Oval	Hook, 1/4" strap	2 5/16" integral	12 Bumps	Off(R)	Thorpe
1912-13-15	Very good	B	Beads	Downturned lever (no stamp) [Lever]	Oval	Hook, 1/4" strap	2 1/2" integral	12 Bumps	Off(R)	Young
1912-13-15	Excellent	B	Beads	"Justrite Leverfeed"	Oval	Hook, 1/4" strap	2 5/16" integral	12 Bumps	Off(R)	Thorpe
1912-13-15	Excellent	N	Beads	"Justrite Leverfeed"	Oval	Hook, 1/4" strap	3" saucer, integral	12 Bumps	Off(R)	Thorpe
1912-13-15	Excellent	N	Beads	"Liberty Trade Mark"	Oval	Superintendent's	2 1/2" integral	12 Bumps	Off(R)	Thorpe
1912-13-15	Good	N	Ribs	"Liberty Trade Mark"	Gasket	Hook, 1/4" strap	3" saucer integral	12 Bumps	Off(R)	Thorpe
1912-13-15	Fair	B	Ribs	"Liberty Trade Mark"	Gasket	Hook, 1/4" strap	2 5/16" integral	12 Bumps	Off(R)	Puhl
1912-13-15	Excellent	N	Ribs	"Liberty Trade Mark"	Oval	Superintendent's	2 1/2" integral	16 Bumps	Off(R)	Thorpe
1912-13-15 (USA)	Good	B	Beads	"Polygon Feed"	Oval	Hook, 1/4" strap	2 1/2" integral	16 Bumps	Off(R)	Thorpe
1912-13-15 (USA)	Excellent	B	Ribs	"Justrite Leverfeed"	Oval	Hook, 1/4" strap	2 5/16" integral	16 Bumps	Off(R)	Thorpe
1912-13-15 (USA)	Excellent	N	Ribs	"Polygon feed Pat.App.For"	Oval	Hook, 1/4" strap	3" saucer integral	16 Bumps	Off(R)	Thorpe
1912-13-15 (USA)	Excellent	N&B	Ribs	"Justrite Leverfeed"	Oval	Hook, 1/4" strap	3" saucer integral	16 Bumps	Off(R)	Thorpe
1912-13-15 (USA)	Good	B	Ribs	"Justrite Leverfeed"	Round	Hook, 1/4" strap	2 5/16" integral	16 Bumps	Off(R)	Thorpe
1912-13-15 (USA)	Poor	B	Ribs	"Polygon feed Pat.App.For"	Round	Hook, 3/16" strap	2 5/16" integral	16 Bumps	Off(R)	Puhl
1912-13-15 (USA)	Good	N	Ribs	"Polygon feed Pat 2-21-22"	Round	Hook, 3/16" strap	3" saucer integral	16 Bumps	Off(R)	Puhl
1912-13-15 (USA)	Good	B	Ribs	"Polygon feed Pat 2-21-22"	Round	Hook, 3/16" strap	2 1/2" (Deep, nickle)	16 Bumps	Off(R)	Puhl
1912-13-15 (USA)	Good	N	Ribs	"Justrite Duplexfeed"	Round	Superintendent's	2 1/2" integral	16 Bumps	Off(R)	Puhl
1912-13-15 (USA)	Excellent	B	Ribs	"Justrite Duplexfeed"	Round	Hook, 3/16" strap	2 5/16" integral	16 Bumps	Off(R)	Thorpe
1912	Excellent	B	Ribs	"Wire feed"	Round	Hook, 3/16" strap	2 5/16" integral	16 Bumps	Off(R) raised	Thorpe
1912	Fair	N	Ribs	"Wirefeed"	Round	Hook, 3/16" strap	2 5/16" integral	16 Bumps	Off(R) raised	Puhl
1912	Good	N	Ribs	"Wirefeed"	Round	Superintendent's	2 1/2" integral	16 Bumps	Off(R) raised	Puhl
1912	Good	N	Ribs	"Polygon feed Pat 2-21-22"	Round	Superintendent's	3"saucer integral	16 Bumps	Off(R) raised	Puhl
1912	Excellent	B	Ribs	"Polygon feed Pat 2-21-22"	Round	Hook, 3/16" strap	2 1/2" integral	16 Bumps	Off(R) raised	Thorpe
1912	Good	N	Ribs	"Polygon feed Pat 2-21-22"	Round	Hook, 3/16" strap	3" saucer integral	16 Bumps	Off(R) raised	Thorpe
1912	Excellent	B	Ribs	"Polygon feed Pat 2-21-22"	Round	Hook, 3/16" strap	2 5/16" integral	16 Bumps	Off(R) raised	Puhl
1912	Excellent	N	Ribs	"Polygon feed Pat 2-21-22"	Ringed	Superintendent's	3"saucer integral	16 Bumps	Off(R) raised	Puhl
1912	Excellent	N	Ribs	"Polygon feed Pat 2-21-22"	Ringed	Hook, 3/16" strap	3" saucer integral	16 Bumps	Off(R) raised	Thorpe
1912	Very good	N	Ribs	"Polygon feed Pat 2-21-22"	Ringed	Hook, 3/16" strap	2 1/2" integral	16 Bumps	Off(R) raised	R.J.
1912	Very good	B	Ribs	"Polygon feed Pat 2-21-22"	Ringed	Hook, 3/16" strap	3" integral (NICKLE)	16 Bumps	Off(R) raised	Puhl
1912	Fair	N	Ribs	"Wire feed"	Ringed	Hook, 3/16" strap	3" saucer integral	16 Bumps	Off(R) raised	Puhl
1912	Good	N&B	Ribs	"Wire feed"	Ringed	Hook, 3/16" strap	2 5/16" integral	16 Bumps	Off(R) raised	Thorpe
1912	Good	N&B	Ribs	"Polygonfeed Pat 2-21-22" Sm.lever	Ringed	Hook, 3/16" strap	3" saucer integral	16 Bumps	Off(R) raised	Puhl
1912	Very good	B	Ribs	"Polygonfeed Pat 2-21-22" Sm.lever	Ringed	Hook, 3/16" strap	3" integral (NICKLE)	16 Bumps	Off(R) raised	Puhl
1912	Excellent	B	Ribs	"Wirefeed" Small lever	Ringed	Hook, 3/16" strap	2 5/16" integral	16 Bumps	Off(R) raised	Thorpe
1912	Very good	B	Ribs	"Polygonfeed Pat 2-21-22" Sm.lever	Ringed	Hook, 3/16" strap	Removable	16 Bumps	Off(R) raised	Puhl
TRADEMARK	Excellent	N&B	Ribs	"Polygonfeed Pat 2-21-22" Sm.lever	Ringed	Hook, 3/16" strap	Removable	16 Bumps	Off(R) raised	Puhl
TRADEMARK	Good	N&B	Protecto	"Wirefeed" Small lever	Ringed	Hook, 3/16" strap	Removable	16 Bumps	Off(R) raised	Puhl
TRADEMARK	Excellent	N&B	Ribs	"Polygonfeed Pat 2-21-22" Sm.lever	Ringed	Hook 3/16" strap	Removable	19 Bumps	Off(R)raised	Thorpe
TRADEMARK	Excellent	B	Ribs	"Justrite" Small lever	Ringed	Narrow spade	Removable	19 Bumps	Off(R) raised	Thorpe
TRADEMARK	Unfired	B	Protecto	"Justrite" Small lever	Ringed	Hook, wire brace	Removable	19 Bumps	Off(R)raised	Thorpe
TRADEMARK	Excellent	N	Protecto	"Justrite" Small lever	Ringed	Hook, wire brace	Removable	19 Bumps	On(R)raised	Thorpe
TRADEMARK	Excellent	N	Ribs	"Justrite" Small lever	Ringed	Hook, wire brace	Removable	19 Bumps	On(R)raised	Thorpe
TRADEMARK	Excellent	B	Cooled	"Justrite" Small lever	Ringed	Hook, wire brace	Removable	19 Bumps	On(R)raised	Thorpe
TRADEMARK	Excellent	B	Ribs	"Justrite" Small lever	Ringed	Narrow spade	Removable	19 Bumps	On(R)raised	Thorpe

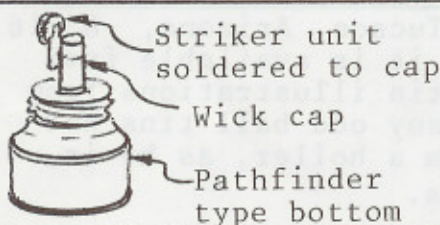

Trades - Charles J. Frase, 1015 Noelton Ln., Nashville, Tenn., 37204, (615)297-0139, has the following for trade: N P Pathfinder alcohol lamp (illustrated); N P mine inspector's Baldwin; and bottoms early smooth-sided Justrite, vertical Grier, Sun Ray, Simmons, Buddy. Needs cap lamps.

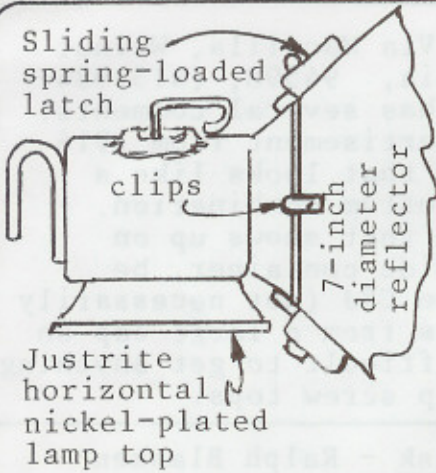

Justrite Reflector - David Johnson, 2415 S. Villa, Indianapolis, Indiana, 46203, has told us about a nickel-plated horizontal Justrite carbide cap lamp with a unique attachment for its 7-inch diameter reflector. The sketch at the left shows two spring-loaded latches and two fixed locating clips for holding the reflector in place.

France - Jean-Claude Delhomme, 5 Allée des Narcisses, 78120 Rambouillet, France, has sent two messages as follows:

- He would like to exchange typical French carbide lamps (Arras, Mercier, La Francaise) and French oil lamps for U S A carbide lamps and candleholders.
- Anyone interested in French old mines, lamps, museums, new books on mines, or interested in corres-

ponding with French or Belgian persons dedicated to mining? All are invited to subscribe to: "Echo des Berlins" a quarterly publication. Send checks for \$15.00 US payable to ACIAI to: ACIAI, 5 Allée des Narcisses, 78120 Rambouillet, France.

Combination - Dave Thorpe has sent the following three items:

- How to determine if your Gem cap lamp reflector is original All Gem cap lamp reflectors have a peculiar mark inside the reflector just eccentric to where the burner tube emerges. It appears as a tiny 1/16 in. (1.59 mm) circle stamped in the metal. In fact, if one looks at the Gee Bee reflector, it becomes apparent that this was, at one time, an indentation designed to hold the reflector firmly against the reflector brace. When the Gem was manufactured, this indentation was hammered back flush, leaving just the appearance of a tiny circle.
- Same dies, different manufacturer?

Certain cap lamps have water tanks of identical dimensions, but were sold by different manufacturers. The most obvious example is the early style AutoLite and the Springfield. Another is the late style AutoLite tank which is identical in dimension to the Elkhorn, and the early style Simmons Pioneer (the type without a reflector brace).

● Cap lamps for trade or sale Dave has the following cap lamps for trade or sale: Grier (vertical and horizontal), Sun Ray, vertical Justrite, set-screw AutoLite, Lu-Mi-Num, I T P, Baldwin pinchwaist, many styles of horizontal Justrites, many styles of Guy's Droppers. For trade only: Force Feed. Buyers - don't expect any bargains! Dave thorpe, 16646 N. 30th Ave., Phoenix, Arizona, 85023.

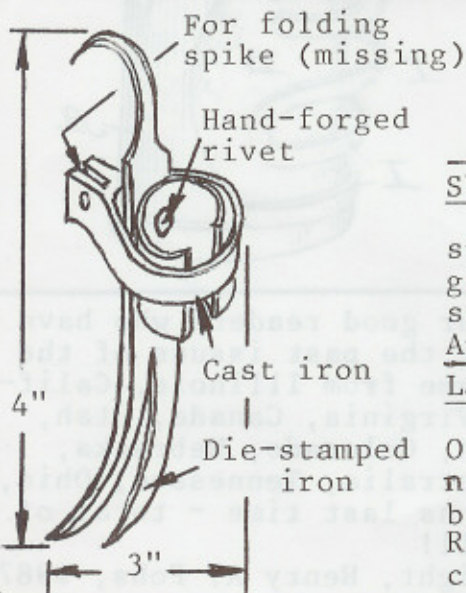

Candlesticks - Ron Bommarito, Box 114, Genoa, Nevada, 89411- (702)782-3893, has sent in the sketch at the left of a partial stick he recently acquired. Ron says that he has some miner's candlesticks for sale on special inquiry.

Show-and-tell - Gene Calman, 3235 Armstrong St., #A17, San Diego, California, 92111, suggests posing the idea that he thinks it would be great for all of the collectors to get together for some sort of a show-and-tell and trading session. Anyone so inclined is invited to contact Gene.

Lamps and Parts Wanted - Edward L. Miner, 1377 Broadway N. E., East Canton, Ohio, 44730, (216)488-2129, writes to say that he needs a screw-on reflector and a press-on reflector, both for Baldwin lamps, a Baldwin bottom, and a Sun Ray nickel-plated bottom. He will buy any type of carbide lamps, candleholders, or mining scrip.

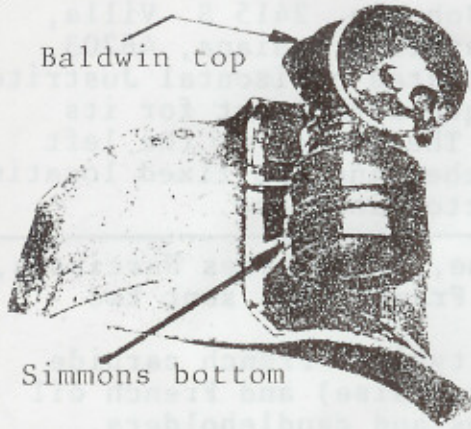

Moonbeams - Tony Moon, 214 Via Mantilla, Walnut Creek, California, 94598, (415)934-2910, (until this summer), has several comments:

- A Pulmosan Respirator advertisement from 1916 shows (left) a strange lamp that looks like a Baldwin top and a Simmons bottom combination.
- On the mystery trade mark that shows up on oil lamps and now on a carbide container, he thinks that the initials are CFJ (not necessarily in that order). He got this from a large cap on a mule lamp. It is very difficult to get anything from the small oil wick lamp screw tops.

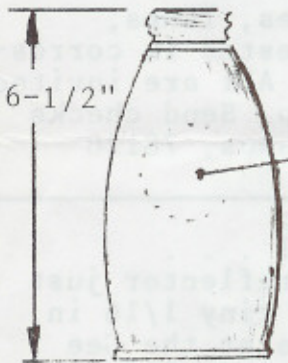

MINER'S OIL FLASK
- MFG -
CHAS. HALL & CO.
NORTON, VA.
PAT. JULY 25, 1905

Oil Flask - Ralph Blankenbecler, Rt. 3, Box 46, Coeburn, Virginia, 24230, has sent a sketch of an oil flask similar to the well-known carbide flasks and with the marking as shown to the left. The hinge design on the top closure is unclear from Ralph's sketch, but it may well be the same as on the carbide tins.

English Patent - Manfred Stutzer, Madenburgstr 6, 6700 Ludwigshafen 15, West Germany, has provided copies of a 1895 English patent for an oil wick cap lamp with an extravagant spout heat conducting device as shown below in two different forms.

Fig. 1.

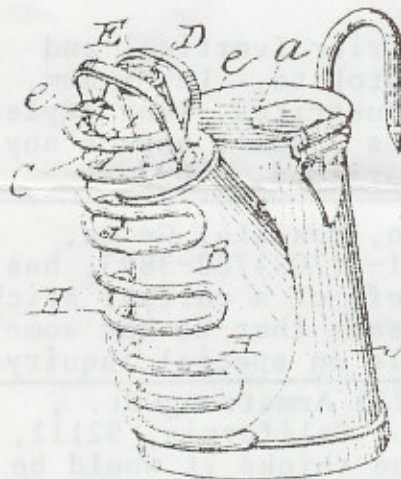

Fig. 2.

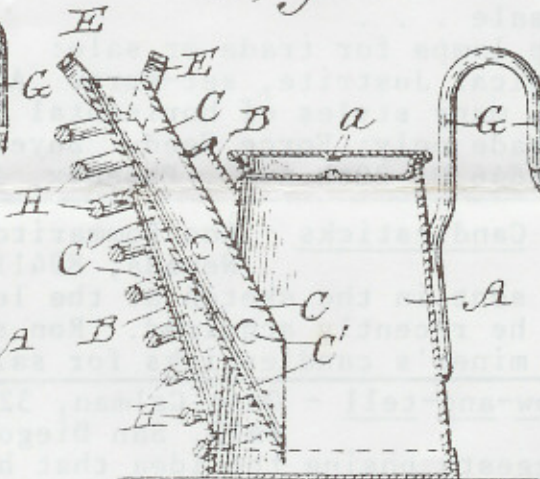
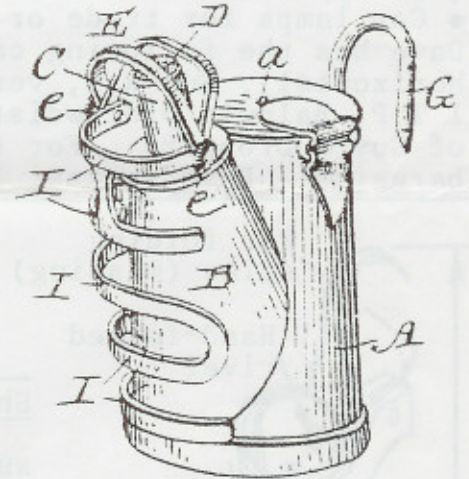

Fig. 3.



Postage and Expenses - Once again we thank all of our good readers who have helped to cover the costs for the past issues of the Lamp Post. Stamps and funds since the last issue came from Illinois, California, Washington, Texas, Missouri, Maryland, West Virginia, Canada, Utah, New York, Virginia, Pennsylvania, Arizona, Michigan, Colorado, Nebraska, Florida, Nevada, Oregon, Alabama, New Hampshire, Australia, Tennessee, Ohio, and Arkansas. Costs for this issue remain the same as last time - total of approximately \$165.00 for 350 copies. Thank you all!

Lamp Post © Copyright, Henry A. Pohn, 1987