

# The Kerckhoff Patent Candlestick

## A Newly Discovered Patented Miner's Candlestick

Wendell Wilson

It is amazing to me that hitherto unknown kinds of mining artifacts continue to turn up after all this time. In fact, in the weeks right after my recent book on miners' candlesticks came off the press, I acquired not one but two candlesticks I had never seen before and had not illustrated in the book. One is the example pictured here. A candlestick that is free of any markings can be difficult to trace; however, this one has an abundance of markings which *should* make historical research easier.



**Kerckhoff patent candlestick with the removable hook in the vertical position**

### **Provenance**

This candlestick (purchased recently on eBay) turned up in a box of junk in an abandoned storage unit in San Diego, suggesting that it may have a California origin. The highgrader's handle, typical of candlesticks from the California gold country, makes that origin even more likely.

### **Construction**

The body of the candlestick is made from one piece of steel, folded around and brazed together at the handle neck in the usual manner of countless other blacksmith sticks. However, it is

mechanically unique in having a brazed-on two-way steel mounting block for attaching the hook. The hook can be removed and repositioned horizontally or vertically, secured in place by a thumb screw. And, as mentioned, it has a wide, scooped-out handle referred to by collectors as a “highgrader’s handle” wherein small bits of gold could be surreptitiously stuck with a dab of candle wax. The thimble lever has a flared design and the shaft of the hook has some minor ornamentation. There are six small notches on the underside of the handle, three on each side. The seller said the thumb screw is a replacement; if so, it is a very good one because it fits perfectly and has an identical patina of black oxide compared to the rest of the stick.



## The Patent

The candlestick is clearly stamped with a complete patent date, “PAT. AUG. 16, 1904.” The gang stamp is small, apparently sized to exactly fit the available space on that part of the stick. It is a previously unknown patent for a miner’s candlestick, probably because that application is not mentioned in the patent papers and consequently does not turn up in a search.

U.S. Patents in those days were granted once a week, and August 16 was one of those days. All patents granted on that date are listed in the *Official Gazette of the United States Patent Office*, Volume 111, number 7; there are 768 of them. Unfortunately *none* of them are identified as having a mining application, nor do any bear an obvious resemblance to a repositionable hook. Simple searches on the words “miner,” “mine,” “mining,” “candlestick,” “candleholder,” or even “candle” turn up no candidates among the 768 patents. Therefore the patented feature must be part of some other application.



Restricting the search to patents granted on that date in California reduces the number of candidates to 21 – from potato slicers to windmill regulators, hose-couplings, briquet-machines, gas valves and cuspidor lifters (!). After studying them all, I realized that the patented feature on the candlestick was not the repositionable aspect of the hook but just the simple locking mechanism for a sliding, beveled track with a set screw: Patent number 767,896, “Adjustable Screen and Sash for Windows” by Herman Henry Kerckhoff of Los Angeles. The mechanism is described in the patent as follows:

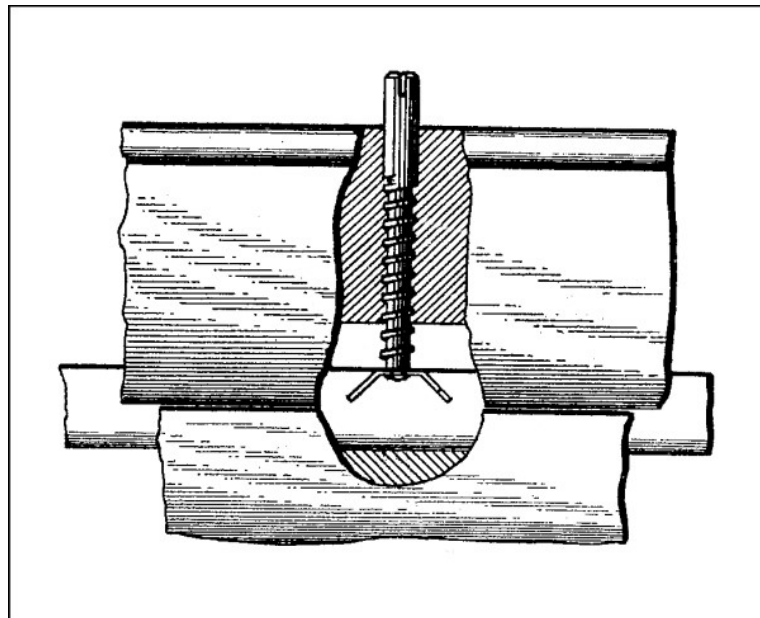

**Patent drawing showing the sliding track stabilized by a set screw**

“The combination of a groove member [the two-way candlestick block] having a hole therethrough, an adjusting screw member extending through the hole [the thumb-screw], a tongue [the hook] fitting movably in the groove, and having a cut-away portion extending inwardly and longitudinally from a side edge [i.e. beveled]...such cut-away portion being open side-wise of the tongue...so as adapted to be slid into said cut-away portion, and said attaching means engaging with the groove to retain said means from sidewise displacement [to secure it from sliding in the groove].



**Note the indentation in the center for seating the point of the thumb screw.**

In the case of this candlestick the screw hole is not through the candlestick block (the thimble would be in the way) but through the base of the hook; the principle is the same. In the patent drawing the head of the locking screw is shown with a slot for a screwdriver, but changing it to a flange to make a thumb screw head would be a natural adaptation for use in the candlestick, so that a screwdriver would not be unnecessary when a miner is repositioning the hook.



**Patentee Henry Herman Kerckhoff (1867-1953)**

### **Herman Henry Kerckhoff**

Herman Henry (Heinrich) Kerckhoff was born in Lingen in the Province of Hanover, Germany on January 20, 1867, and came to the U.S. as an infant in 1868 with his parents, Georg and Philippine (Neuhart) Kerckhoff. They arrived in the port of New York aboard the *S.S. Hansa* on August 31, and initially settled in Indiana. The family moved to Los Angeles while Herman was still a boy; there he graduated from high school in 1884 and attended the University of California, majoring in Chemistry (his “class yell” was “Ha! Ha! Ha! Eureka!”—he served as class treasurer). After three years there he left without graduating (in 1888) to take a tour of Europe, and after his return he went to work as a clerk in his elder brother’s business, the Kerckhoff-Cuzner Lumber and Mill Company. In October 1899 he married Anne May Wethern; they appear on the 1900 census for Los Angeles, Herman listing his occupation as a “lumber merchant.” Herman and Annie had two sons, Herman Henry Kerckhoff Jr. (1905-1992) and Stephen Kerckhoff (1901-1967).

In 1900 he established the Hipolito Screen and Sash Company, serving as president—which explains the initial development and use of his patented invention. Herman applied for his patent on July 18, 1902 and received it over two years later. The 1910 and 1920 censuses list him as a “manufacturer” with a “sash and door company.” But he also had an interest in mining; in 1912 he established the Avawatz Salt & Gypsum Company, with the intention of erecting a modern salt refinery and building a 16-mile railroad to Death Valley. The company’s holdings there

included 2,450-acres of high-grade halite, gypsum and celestine deposits in the Avawatz Mountains, located in the Mojave Desert of San Bernardino County. Railroad construction and mining ceased permanently with the outbreak of World War I, but the 1930 census still lists Kerckhoff as a “developer, mineral deposits”—a long-term involvement that no doubt inspired his adaptation of his window sash patent to the design of a miner’s candlestick. By 1940, at age 73, he had retired from his activities in the wholesale lumber business. Herman Kerckhoff died in Los Angeles on April 1, 1953.

## Rarity

Apparently this is only the second example made, as it is stamped “No. 2” above the patent date. I have never seen another example, and have no evidence to suggest that more than two were made. The location of No. 1 remains unknown.

## The Maker



Another name is also stamped on the mounting block, on the other side of the hook from the patent date. This one is also applied with a gang stamp—like the patent date, but sized in larger letters to fit the available space, suggesting that it might be the name of the seller or the maker (miners rarely had their own gang stamp). It says “W. GROW” and below that a partial impression of the same stamp showing only the last three letters, “ROW”. Apparently this lower impression was the first strike,

which didn’t take well, so it was struck a second time to show the full name.

“Grow” is a fairly rare surname. The fact that the candlestick was found in California, that it has a California-style highgrader’s handle, and was patented by a California resident all suggest that the search for “W. Grow” should center on California.

There is William B. Grow, listed in the 1900 census (born Dec. 1861) for Ventura, California, and employed there as a machinist. In the 1901 Philadelphia City Directory he is listed living at the same address (perhaps just visiting family) with two blacksmiths, John William Grow and Cyrus Franklin Grow. All of them ultimately moved to California. By 1922, William B. Grow was listed in the City Directory for Yuba, California, as a machinist working for (or perhaps owning) the Yuba Construction Company (called the Yuba Manufacturing Company after 1917)—they had a “big iron works out on twelfth street” employing over 100 men. By the 1930 census he was aged 69, living in Marysville, Yuba County, and identified as a machinist working in his “own shop.” He was an inventive sort, and had been granted at least two patents—in 1901 for a well-driving device, and in 1926 for a hand truck. He was an early automobile enthusiast,

and his manufacturing company also eventually made tractors. He died in 1934 and is buried in Sutter, California. There is no evidence that he was connected with mining in any way; but he or an employee could have been the maker of the candlestick, providing ironware to the local gold miners.

Or, if the gang stamp does indeed refer to a miner who owned it, the 1900 California Census shows a gold miner by the name of William S. Grow, born in Germany in 1865 and living in Downieville, Sierra County. He had immigrated to the U.S. in 1882. There are only three other men named William Grow on that census, none of them working as miners or blacksmiths. But in rare cases miners have had enough blacksmithing skill to fashion a candlestick, so who knows?

At this point we can offer only speculation, as there is no hard evidence regarding who crafted this candlestick. All we can say for certain is that the maker was an experienced and skilled blacksmith who had made candlesticks before. After all, the highgrader's handle is not a part of the patent; only someone with previous experience making miners' candlesticks would include it. It is quite possible that "W. Grow," whoever he was, made the candlestick, probably through a connection with the patentee Herman Kerckhoff. In any case, the maker was probably a blacksmith or a machinist and not a miner. As mentioned, miners rarely had gang stamps made of their own name, but a blacksmith would.



### **The Owner**

The initials of a presumed owner, "PMD," stamped one letter at a time, appear in two places. In one case the letters are stamped (clearly but rather poorly) using individual letter stamps that jittered around under several blows, leaving multiple impressions. In the other case they are spelled out using a die punch, one dot at a time.

**The punched name on the spike. Can you read it?**

More frustrating is the die-punched lettering on the side of the spike, which is so crudely and poorly done that, even though each dot is clear enough, it is virtually impossible to recognize what all the letters are supposed to be, or even which way is up. My best guess is that it says “Pedro” (up-side-down) which would fit with the PMD initials also applied with a punch, but I could be wrong.

It is highly unlikely that “PMD” was the maker of the stick, as his signature initials are much too crude for such a skilled blacksmith.



**Hook stowed in the horizontal position**

### **Sources**

U.S. Federal Census Records

Western Edition *Notables of the West*, Vol. I, page 94.

International News Service, New York, Chicago, San Francisco, Los Angeles, Boston, Atlanta (1913).

*Official Gazette of the United States Patent Office*, Volume 111, number 7:

[https://www.google.com/books/edition/Official\\_Gazette\\_of\\_the\\_United\\_States\\_Pa/1W4bAQAAMAA](https://www.google.com/books/edition/Official_Gazette_of_the_United_States_Pa/1W4bAQAAMAA)

Online Archive of California

*Men of the Pacific Coast, containing Portraits and Biographies of the Professional, Financial and Business Men of California, Oregon and Washington, 1902-1903.* (1903) Pacific Art Company, page 382.